

INSTALLATION AND OPERATING INSTRUCTIONS

- ↳ SANIT S 100 - 300
- ↳ SANIT SE 100 - 300
- ↳ SANIT DC 100 - 250
- ↳ SANIT DCE 100 - 250
- ↳ SANIT HE 150 - 300
- ↳ SANIT HE 150 - 300 DS

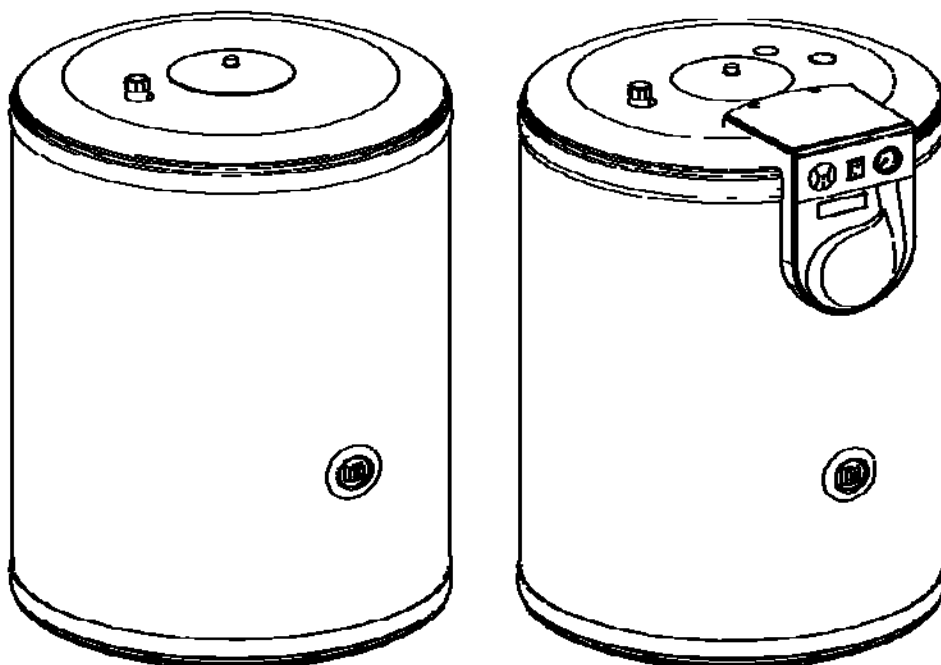

DOMUSA
T E K N I K

Thank you for choosing a **DOMUSA TEKNIK** product. From the range of **DOMUSA TEKNIK** products you have chosen the **Sanit** model, a stainless steel hot water tank for producing domestic hot water (DHW), which together with a **DOMUSA TEKNIK** heating boiler will provide the ideal level of comfort for your home.

This manual forms an essential part of the product and it must be given to the user. Read the warnings and recommendations in the manual carefully, as they contain important information on the safety, use and maintenance of the installation.

These hot water tanks are to be installed by skilled personnel only, in accordance with the legislation in force and following the manufacturer's instructions.

The start-up of these hot water tanks and any maintenance operations must only be carried out by **DOMUSA TEKNIK's** Authorised Technical Assistance Services.

Incorrect installation of these hot water tanks could result in damage to people, animals or property, and the manufacturer will hold no liability in such cases.

CONTENTS

	Pág.
1 SAFETY COMPONENTS.....	2
1.1 FROST PRECAUTIONS	2
1.2 WATER CHARACTERISTICS	2
2 LIST OF COMPONENTS.....	3
3 CONTROL COMPONENTS (ONLY SANIT SE AND SANIT DCE)	7
4 INSTALLATION INSTRUCTIONS.....	8
4.1 HYDRAULIC INSTALLATION	8
4.2 SANIT SE, SANIT S, SANIT HE AND SANIT HE DS INSTALLATION	8
4.3 SANIT DCE INSTALLATION	9
4.4 LOCATION	11
4.5 EQUIPMENT / OPTIONS	11
4.5.1 Cathodic protection	11
4.5.2 S 200 and Sanit S hydraulic kits	11
4.5.3 Electrical element (Sanit S and Sanit SE)	12
4.5.4 Electrical element kit (Sanit DCE and Sanit DC in horizontal or wall position).....	12
4.5.5 Electrical element kit (Sanit DCE and Sanit DC in floor position).....	12
5 OPERATION (ONLY FOR SANIT SE AND SANIT DCE)	13
6 DIAGRAM AND ELECTRICAL CONNECTION (ONLY FOR SANIT SE AND SANIT DCE)	13
6.1 ELECTRICAL DIAGRAM.....	13
6.2 ELECTRICAL CONNECTION TO THE BOILER	14
6.3 DIAGRAMS FOR CONNECTION TO DOMUSA TEKNIK BOILERS:.....	14
6.4 INSTRUCTIONS FOR ELECTRICAL CONNECTION OF THE SANIT STORAGE HEATER TO THE FOLLOWING BOILERS:.....	15
7 DRAINING THE TANK.....	16
8 MAINTENANCE	17
9 START-UP	17
10 DELIVERY OF THE INSTALLATION	17
11 SPARES LIST	18
11.1 HOT WATER TANK.....	18
11.2 PLUGS AND EMBELLISHER	21
11.3 ELECTRICAL BOARD (SANIT SE AND SANIT DCE)	22
12 DIAGRAMS AND MEASUREMENTS	23
13 TECHNICAL CHARACTERISTICS	26

Sanit

1 SAFETY COMPONENTS

Sanit tanks must be installed by qualified staff in compliance with applicable regulations.

Any work must be carried out by the official Technical Assistance Service, as any changes to its configuration could cause functioning errors and could damage the system and its surrounding environment.

This appliance can be used by children aged from 8 years and above and persons with reduced physical, sensory or mental capabilities or lack of experience and knowledge if they have been given supervision or instruction concerning use if the appliance in a safe way and understand the hazards involve. Children shall not play with the appliance. Cleaning and user maintenance shall not be made by children without supervision.

The electrical main power supply connection must respect the current legislation, making possible a complete disconnection of the tank, in order to make any maintenance operation safely. Look "Electrical connection" chapter.

1.1 Frost precautions

When there is danger of frost, and particularly in areas with very low temperatures, precautions will need to be taken to prevent damage to the installation. It is recommendable to add anti-freeze to the water in the primary circuit of the tank. The anti-freeze used must be compatible with public health regulations and it must not be toxic. **DOMUSA TEKNIK** recommends the use of propylene glycol, consulting the product manufacturer before use.

If the installation is to be out of use for a long period, **drain all the water from the tank.**

1.2 Water characteristics

The water must comply with the characteristics defined in the Technical Building Code, and must be treated if necessary.

The water must be in accordance with Directive EU 2020/2184 on the quality of water intended for human consumption. Special attention must be paid to the following parameters:

- Maximum chloride concentration: 250 mg / l.
- Maximum sulphate concentration: 250 mg / l.
- Maximum concentration of chlorides and sulphates: 300 mg / l.
- Maximum conductivity: 600 μ S / cm.

When the chlorine concentration in the Domestic Water exceeds 250 mg/dm³, it is recommended that anti-corrosion protection should be applied to the inside of the inter-accumulator so as to avoid its premature deterioration. As an option DOMUSA TEKNIK supplies electronic cathodic protection that is suitable for the Sanit inter-accumulator range. To install it, read carefully the assembly instructions that are provided with the same.

2 LIST OF COMPONENTS

Sanit S / SE

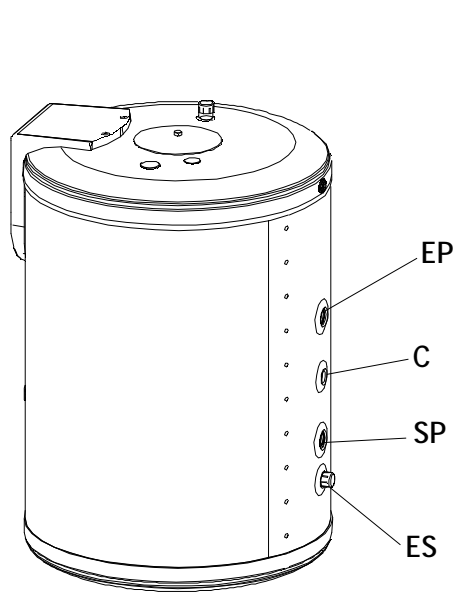
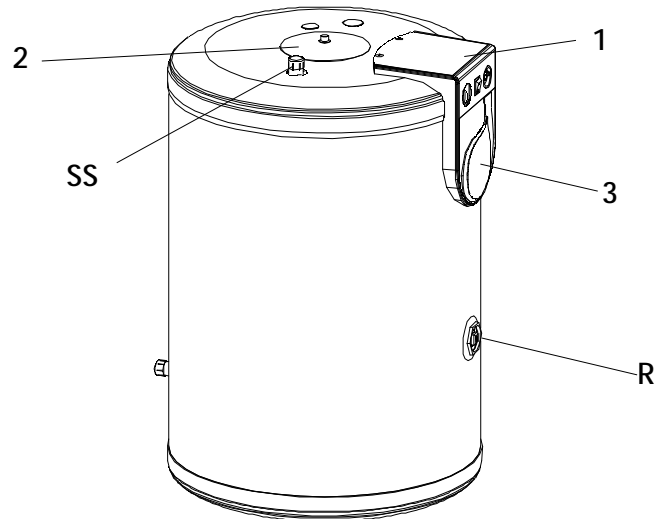

100

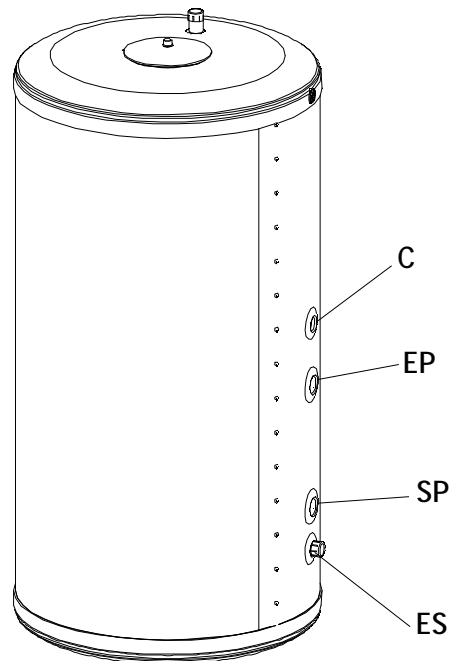

150 to 300

- 1. Front cover (only Sanit SE).
- 2. Bridge cover.
- 3. Control panel (only Sanit SE).

- SP: Primary outlet.
- EP: Primary inlet.
- ES: Domestic cold-water inlet.
- SS: Domestic hot water outlet.
- R: Resistance socket.
- C: Recirculation socket.

Sanit DCE/ DC

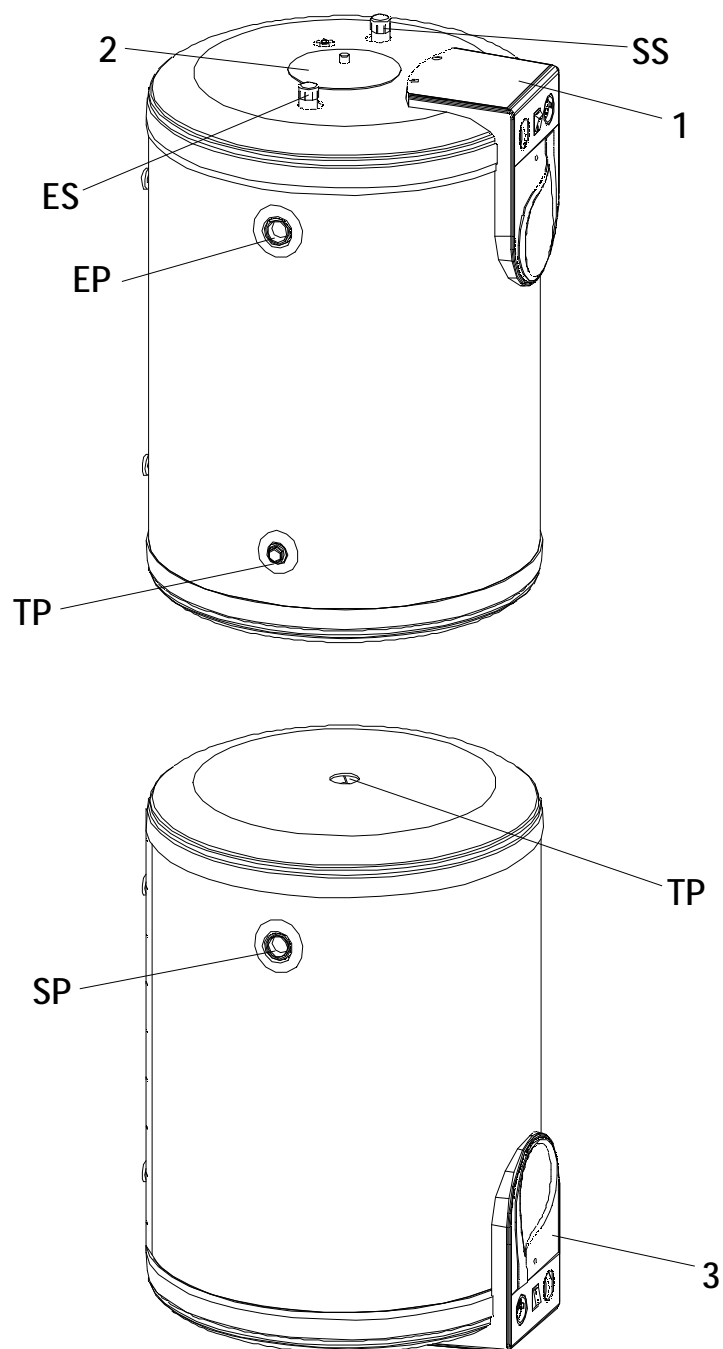

- 1. Front cover.
- 2. Bridge cover.
- 3. Control panel.

- SP: Primary outlet.
- EP: Primary inlet.
- ES: Domestic cold-water inlet.
- SS: Domestic hot water outlet.
- TP: Drain valve socket.

Sanit HE

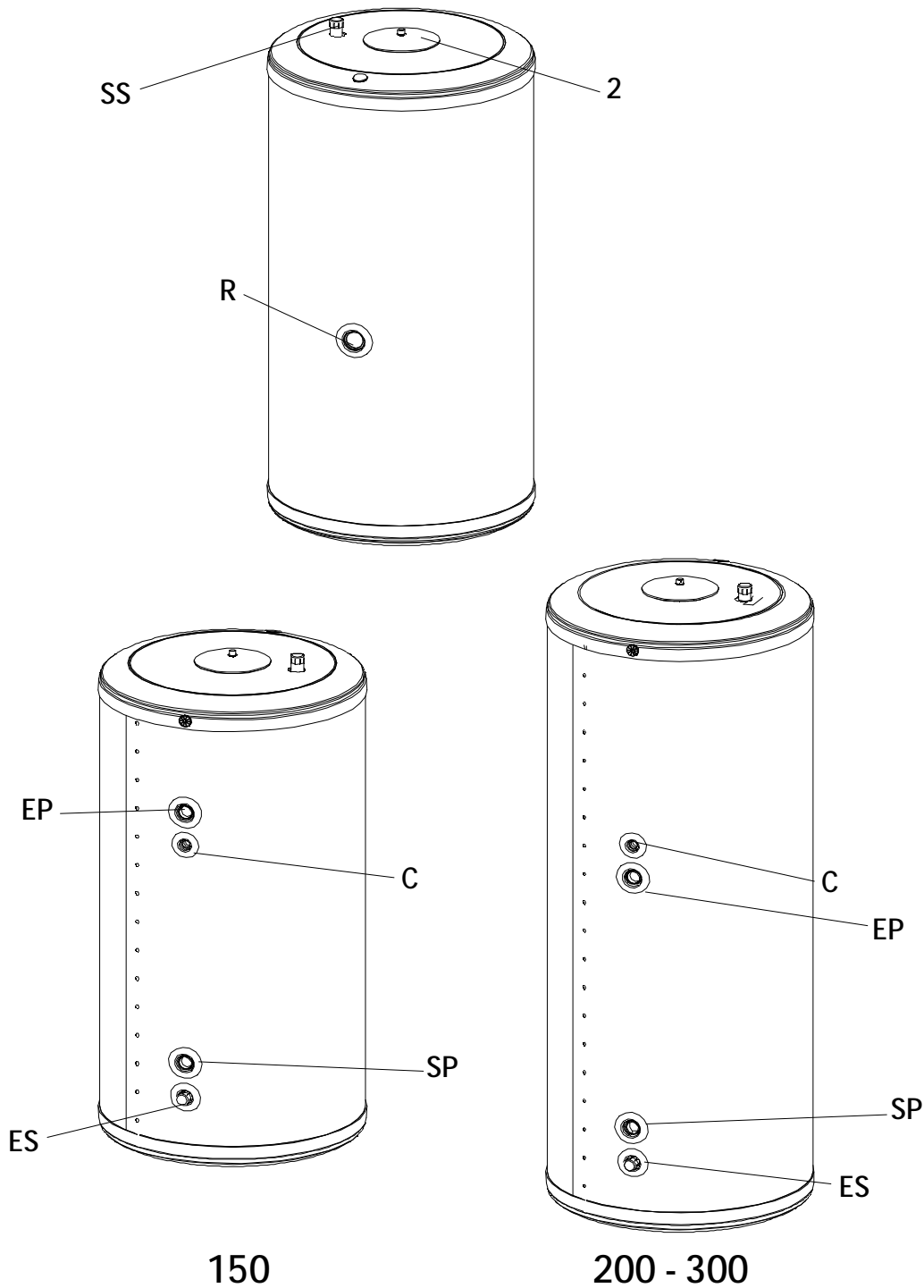

2. Bridge cover.

SP: Primary outlet.

EP: Primary inlet.

ES: Domestic cold-water inlet.

SS: Domestic hot water outlet.

R: Resistance socket.

C: Recirculation socket.

Sanit HE DS

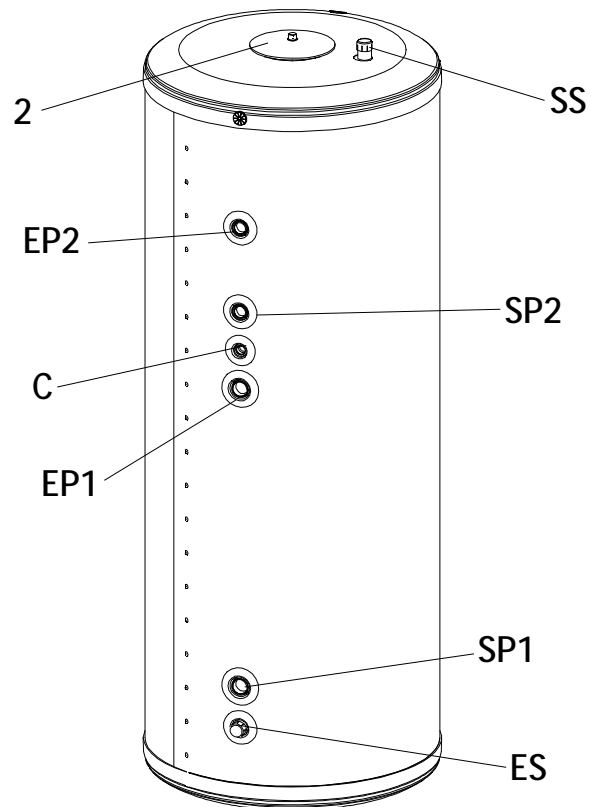

2. Bridge cover.

SP1: Main primary outlet.

EP1: Main primary inlet.

SP2: Auxiliary primary outlet.

EP2: Auxiliary primary inlet.

ES: Domestic cold-water inlet.

SS: Domestic hot water outlet.

C: Recirculation socket.

3 CONTROL COMPONENTS (ONLY SANIT SE AND SANIT DCE)

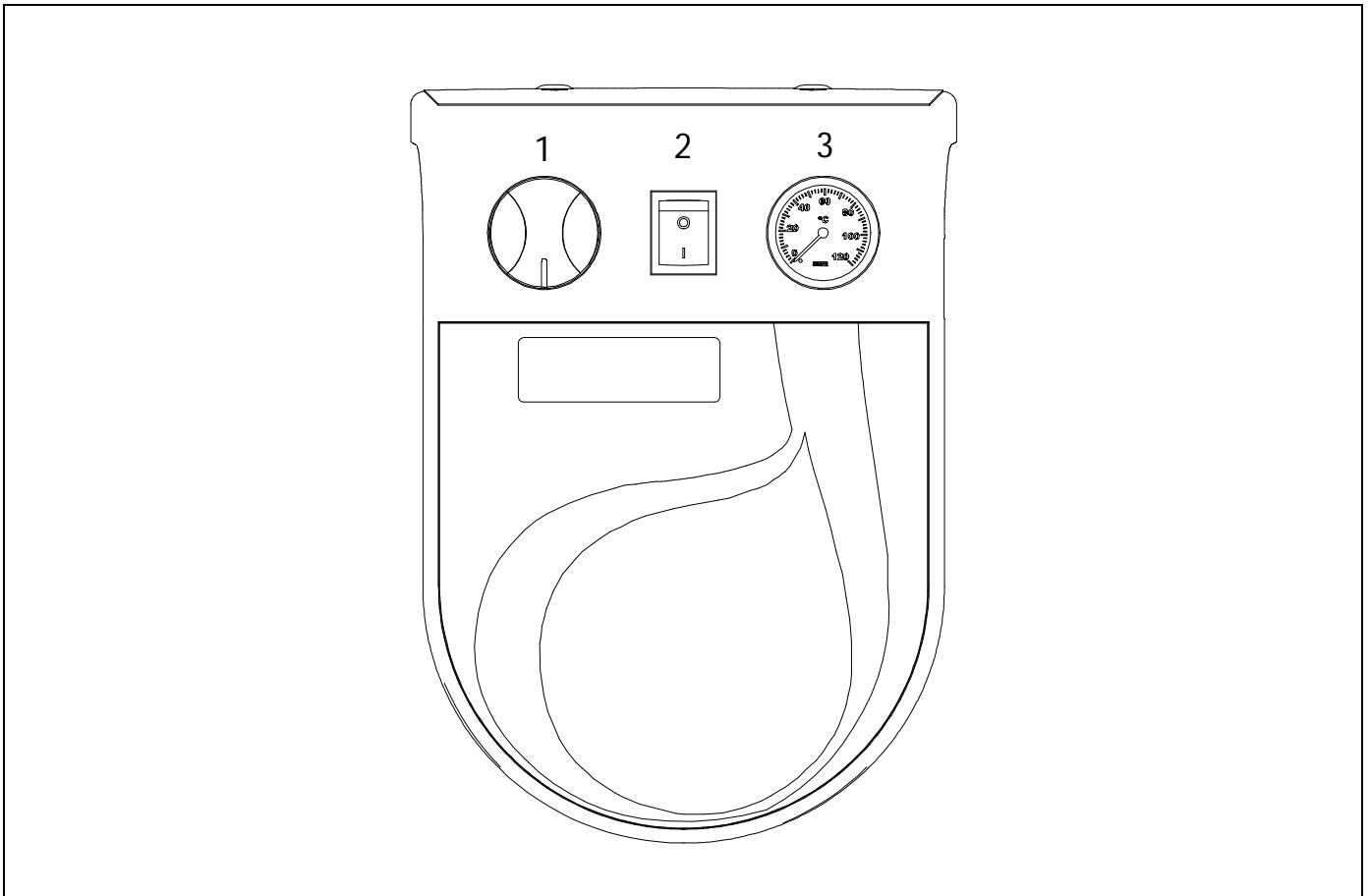

1. Adjustment thermostat:

This control is for adjusting the desired temperature of the hot water stored in the tank.

2. Element switch:

This is for starting up and stopping the optional back-up element of the hot water tank.

3. Thermometer:

This indicates the temperature of the hot water stored in the tank.

4 INSTALLATION INSTRUCTIONS

4.1 Hydraulic installation

The DHW circuit of the accumulator is prepared for permanent connection to the mains water supply through the cold-water inlet. For more information in this area, please refer to the “Technical Characteristics” section, where the maximum pressures are indicated.

The hydraulic installation must be made by qualified technicians, in compliance with current installation regulations and taking the following recommendations into account:

- The secondary circuit (or domestic water circuit) is to be equipped with a safety valve, calibrated to a maximum of 7 bar.
- The safety valve outlet must always lead to a drain.
- To avoid continuous leaking from the D.H.W. safety valve, we recommend the installation of a D.H.W. expansion cell.
- The primary circuit (or heating circuit) for the double chamber tanks must be provided with a safety valve, calibrated to a maximum of 3 bar.
- **After installing the tank, firstly fill and pressurise the secondary circuit (domestic water circuit).**
- **After doing so, proceed to fill the primary circuit. Ensure the secondary circuit is full before filling the primary circuit.**
- Place dielectric sleeves on the secondary circuit connections.
- If the cold-water pressure is higher than the pressure the appliance is designed for, a pressure reducer should be installed, calibrated to no higher than the design pressure.
- To prevent heat loss through the hot water pipes in accumulation systems, an anti-thermal siphon must be installed at the hot water tank outlet. The hot water pipe must be insulated (at least up to the anti-thermal siphon).
- A copper return circuit should not be used.

To drain the hot water tank, first drain the primary circuit and then the secondary circuit.

4.2 Sanit SE, Sanit S, Sanit HE and Sanit HE DS installation

The design of the hot water tank enables it to be installed in three different positions. In the case of the Sanit SE, Sanit S, Sanit HE and Sanit HE DS lines, the accumulator will be installed on the floor, in the vertical position. The sockets for hydraulic connection are as shown in the “LIST OF COMPONENTS” section”.

4.3 Sanit DCE installation

The design of the hot water tank enables it to be installed in three different positions. In the case of the Sanit DCE range, the installation of the tank will be made on the wall, either horizontally or in a wall position (vertical - inverted), with the sockets facing downwards.

For horizontal installations, the hot water tank's performance will be reduced at maximum flow, and a larger hot water tank should therefore be acquired in such cases.

Horizontal installation

For horizontal installation, the hot water tank is equipped with two fixing elements for anchoring it to the wall. In this case, the secondary circuit inlet and outlet sockets are different from those of the vertical installation, and this must be taken into account when making the hydraulic connection.

The screws for wall-mounting the appliance are not included, as the type of screws to be used vary depending on the particular wall.

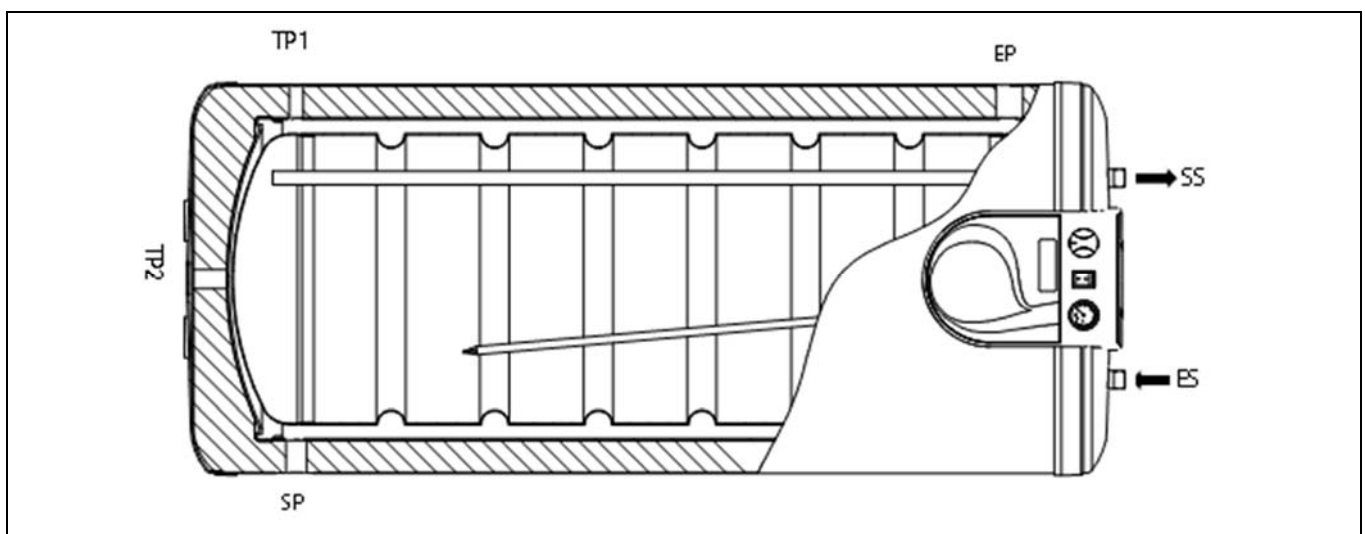

A drain valve should be fitted to the socket TP1 to evacuate any air remaining at the top of the hot water tank.

To drain the primary circuit, and for optimum hot water tank performance, the tank should be positioned as shown in the figure above. At the same time, insert the thermostat and thermometer sensor in the bulb-holder sheath, pushing it down as far as it will go.

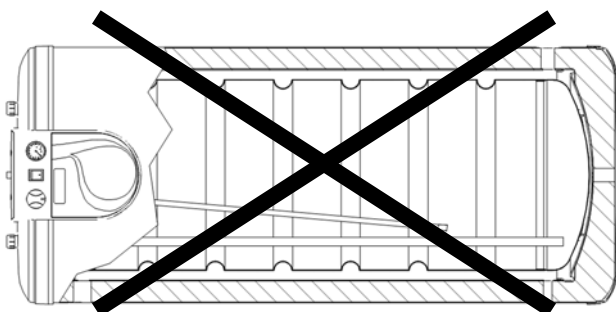

The horizontal drain valve is eliminated in this type of installation, and so the secondary circuit cannot be drained.

Sanit

Wall and floor installation:

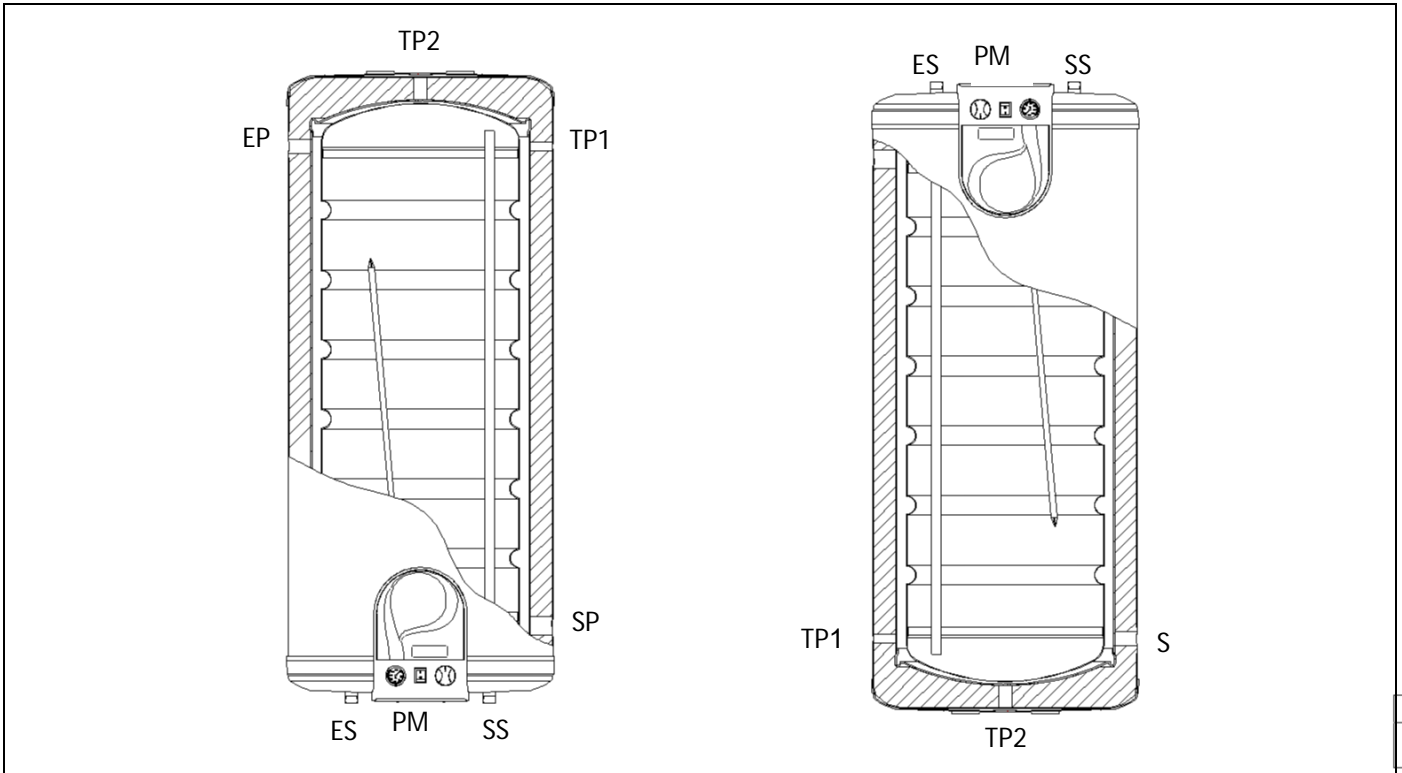

If the installation is made with the hot water tank standing on the floor, the drain valve DV could be used, and the rest of the sockets will be as shown.

IMPORTANT: It is essential to leave enough space above the accumulator, in order to manipulate the elliptical cover.

For the wall installation, position the hot water tank against the wall with the sockets facing downwards. The inlet and outlet sockets of the secondary circuit will be as indicated in the previous figure, and the drain valve socket TP2 must be used. As in the case of the horizontal installation, the hot water tank has two fixings elements for anchoring it to the wall.

IMPORTANT: To unscrew the cap of the TP2 socket, we recommend using a socket wrench.

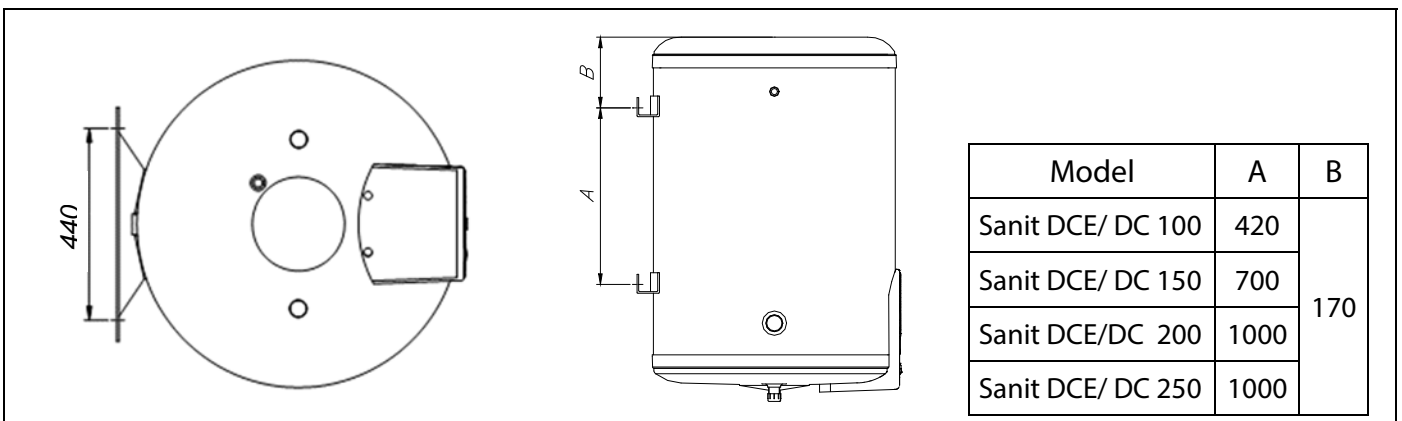

In this case, the insertion depth of the thermostat and thermometer sensor will need to be reduced, as it is originally supplied for a floor installation. The sensor insertion depth for each model is shown below.

	Sanit DCE/ DC 100	Sanit DCE/ DC 150	Sanit DCE/ DC 200	Sanit DCE/ DC 250
Insertion depth	215mm	315mm	415mm	515mm

4.4 Location

The hot water tank must not be installed outdoors or in a place where it may be exposed to weather inclemencies.

To optimise energy use, the hot water tank should be installed as close as possible to the hot water generator.

When choosing a location, taken into account the weight of the full hot water tank, and make sure it is protected against frost. The pipes should be lagged in compliance with heating regulations.

For wall-mounted and horizontal installations, ensure the type of wall to which the hot water tank is fixed can withstand the weight of the tank when full, and choose the most suitable fixing system depending on the wall in question.

4.5 Equipment / options

Although Sanit units are equipped with all the necessary components for functioning, **DOMUSA TEKNIK** offers several optional components for cases in which special features are required.

4.5.1 Cathodic protection

If the chloride concentration in the domestic hot water is higher than 250 mg/cm^3 , we recommend installing a cathodic protection inside the storage heater to avoid premature wear to the hot water tank. **DOMUSA TEKNIK** optionally supplies a suitable electronic cathodic protection for its range of storage heaters. To install it, carefully read the assembly instructions supplied with the cathodic protection.

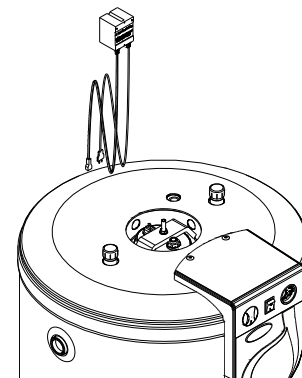

Figure 1

4.5.2 S 200 and Sanit S hydraulic kits

Due to the increase in the temperature of the water stored in the hot water tank can cause the pressure in the tank to increase. **DOMUSA TEKNIK** therefore recommends fitting the S 200 or Sanit S hydraulic kit consisting of dielectric sleeves, a DHW expansion tank and a safety unit, to protect the hot water tank. To install it, carefully read the assembly instructions supplied with the kit.

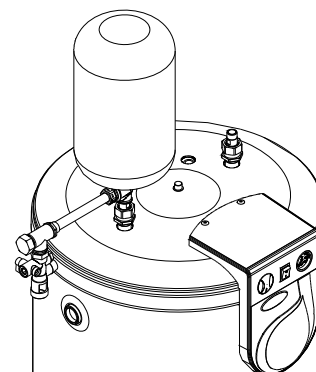

Figure 2

Sanit

4.5.3 Electrical element (Sanit S and Sanit SE)

In the Sanit S and Sanit SE hot water tanks have a socket for connecting an electrical element. **DOMUSA TEKNIK** optionally supplies three elements, of 1.5 kW, 2.5 kW and 3.5 kW. To install them, carefully read the assembly instructions supplied with the elements.

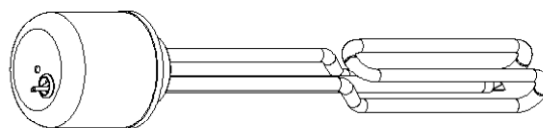

Figure 3

4.5.4 Electrical element kit (Sanit DCE and Sanit DC in horizontal or wall position)

In the Sanit DCE and Sanit DC hot water tanks installed in horizontal or wall position, the electrical element kit will be placed replacing the elliptical cover of the hot water tank. **DOMUSA TEKNIK** optionally supplies three elements, of 1.5 kW, 2.5 kW and 3.5 kW. To install them, carefully read the assembly instructions supplied with the elements.

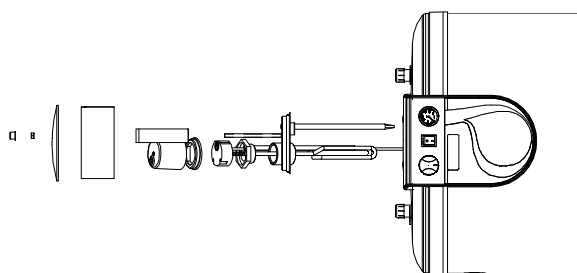

Figure 4

4.5.5 Electrical element kit (Sanit DCE and Sanit DC in floor position)

In the Sanit DCE and Sanit DC hot water tanks installed in floor position, the electrical element kit will be placed replacing the elliptical cover of the hot water tank. **DOMUSA TEKNIK** optionally supplies three elements, of 1.5 kW and 2.5 kW. To install them, carefully read the assembly instructions supplied with the elements.

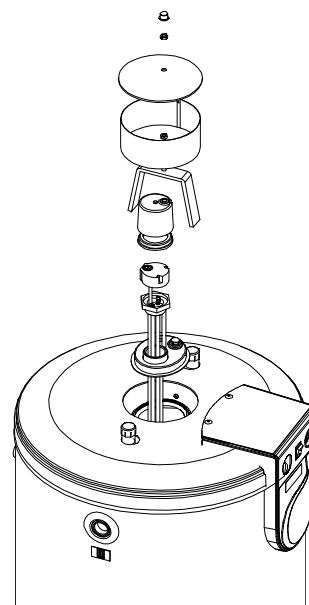

Figure 5

IMPORTANT: To place the resistance on the elliptical cover, it is essential to have a minimum height above the top cover.

	Sanit DCE/ DC 100	Sanit DCE/ DC 150	Sanit DCE/ DC 200/250
Height min. from the top cover	450 mm	700 mm	950 mm

5 OPERATION (ONLY FOR SANIT SE AND SANIT DCE)

The **Sanit** range of hot water tanks is specially designed for use with a wide range of solar power elements, heat pumps and boilers powered by any type of fuel.

If the tank is connected to a DOMUSA TEKNIK brand heating boiler, the boiler will be equipped with a summer or winter position switch, which is used to choose between:

- **Summer position** ☀: in this position the boiler will only produce hot water as needed. The burner and feed pump of the storage heater (summer pump) will be switched on until the hot water stored reaches the temperature set on the hot water thermostat of the storage heater. When this temperature is reached, the burner and the summer pump will switch off.
- **Winter position** ❄: in this position the boiler will produce hot water as needed and will also cater for the heating installation, giving priority to hot water production.

6 DIAGRAM AND ELECTRICAL CONNECTION (ONLY FOR SANIT SE AND SANIT DCE)

The special design of its electrical connections enables the boiler/hot water tank unit to provide heating and domestic hot water with automatic functioning, incorporating a hot water priority function to the joint operation of the two appliances.

When installing the supply cable, take the hot water tank element into account. Different tanks may have different elements, and a different cable diameter is recommended for each type:

Element	Cable diameter
1500 W	1.5 mm ²
2500 W	2.5 mm ²
3500 W	4 mm ²

6.1 Electrical diagram

The electrical connection of **Sanit** tank must be made by qualified staff, and any modifications may only be made by the official technical assistance service (230 V~ 50 Hz). **Do not forget to make the ground connection.**

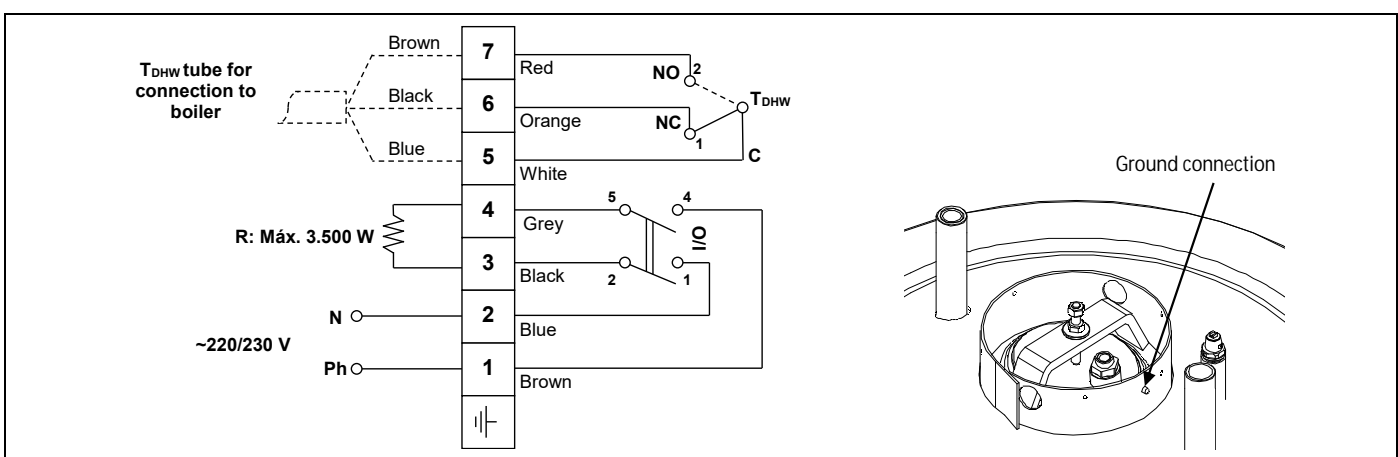

R: Support element, maximum 3500 W.

O/I: Support element switch.

T_{DHW}: Domestic hot water thermostat.

Sanit

6.2 Electrical connection to the boiler

The electrical connection between **Sanit** hot water tanks and **DOMUSA TEKNIK** heating boilers is made by simply connecting the tube shown in the electrical diagram, i.e. the T_{DHW} tube.

Connect the tube to the side of the hot water tank as shown in the electrical diagram in section 6.1.

On the side of the boiler, connect the supply tube of the feed pump (1) mounted on the installation to the terminals bearing the letters "BV" (Summer Pump) according to the electrical diagram for each model of boiler (see the boiler instructions manual). To connect the T_{DHW} tube, first remove the bridges from the boiler connector block and then connect the T_{DHW} tube as shown in the figures below, depending on the boiler model.

6.3 Diagrams for connection to DOMUSA TEKNIK boilers:

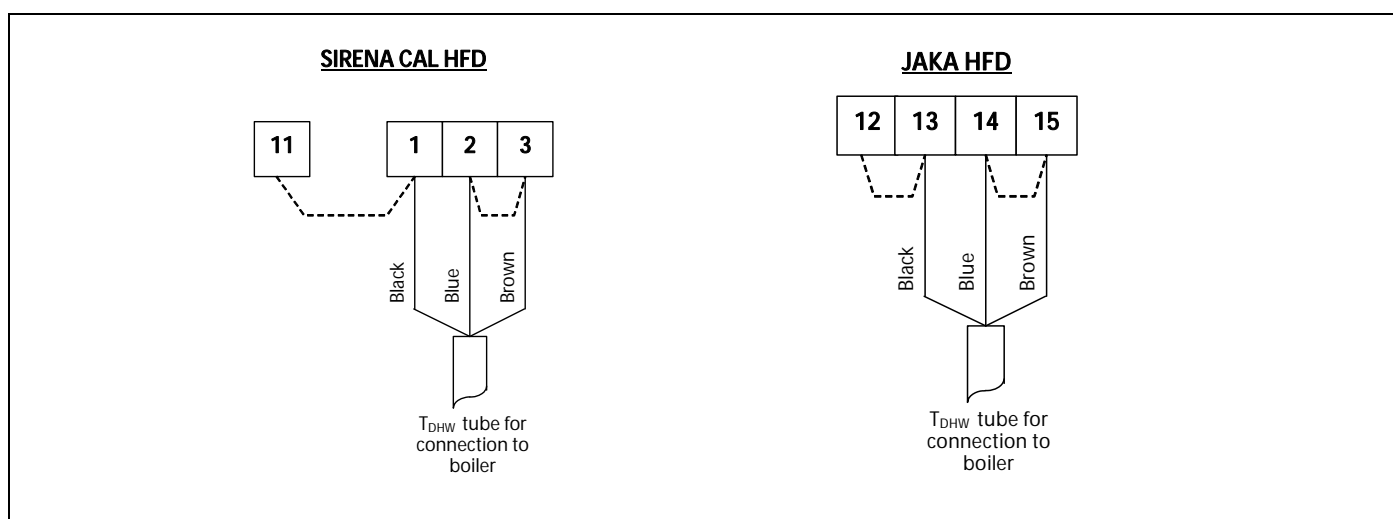

6.4 Instructions for electrical connection of the SANIT storage heater to the following boilers:

- Evolution EV HFC
- Evolution EV HAC
- Sirena Cal He
- Sirena Cal HV e

The correct process for the electrical connection of the **SANIT** hot water storage heater to these boilers is as follows:

- Connect the hot water temperature sensor (supplied optionally) to the sensor connector block **J3 on the boiler** (terminals 13 and 14). To do this, first remove the element (**Ra**) supplied with it (see "Connection Diagram").
- Remove the thermostat bulb from the bulb-holder on the storage heater, and insert the temperature sensor bulb in its place.
- Connect the storage heater feed pump to the boiler supply connector block **J2** (terminals 6 and 7) (see the "Connection Diagram")

For a correct hydraulic installation, carefully follow the assembly and connection instructions supplied with the storage heater.

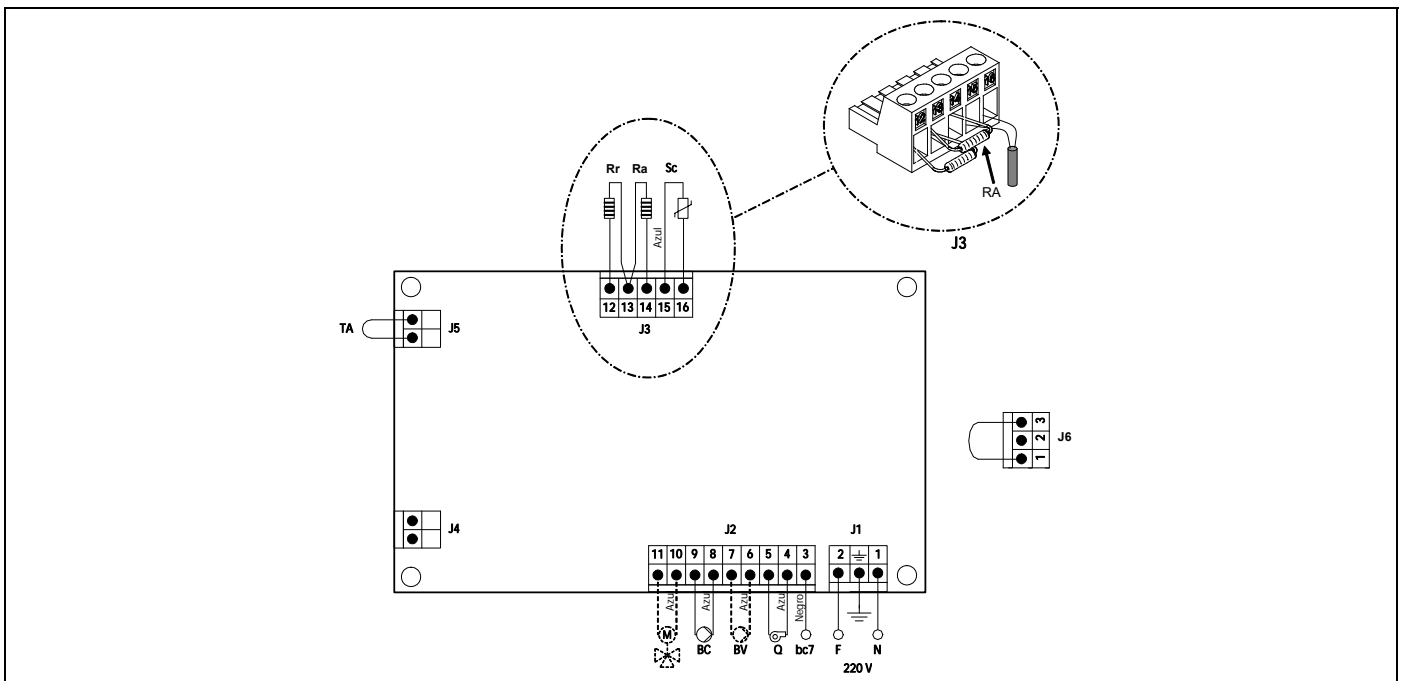

Sanit

7 DRAINING THE TANK

To drain the tank, on the **Sanit SE, Sanit S, Sanit HE and Sanit HE DS models**, a hose must be connected to the cold-water inlet.

Check that the hose is securely fastened to the socket. Next, the lower opening of the hose should be placed in a nearby floor drain, so that the drain is at a lower level than that of the base of the tank. Once the water starts flowing, wait until the tank is completely empty.

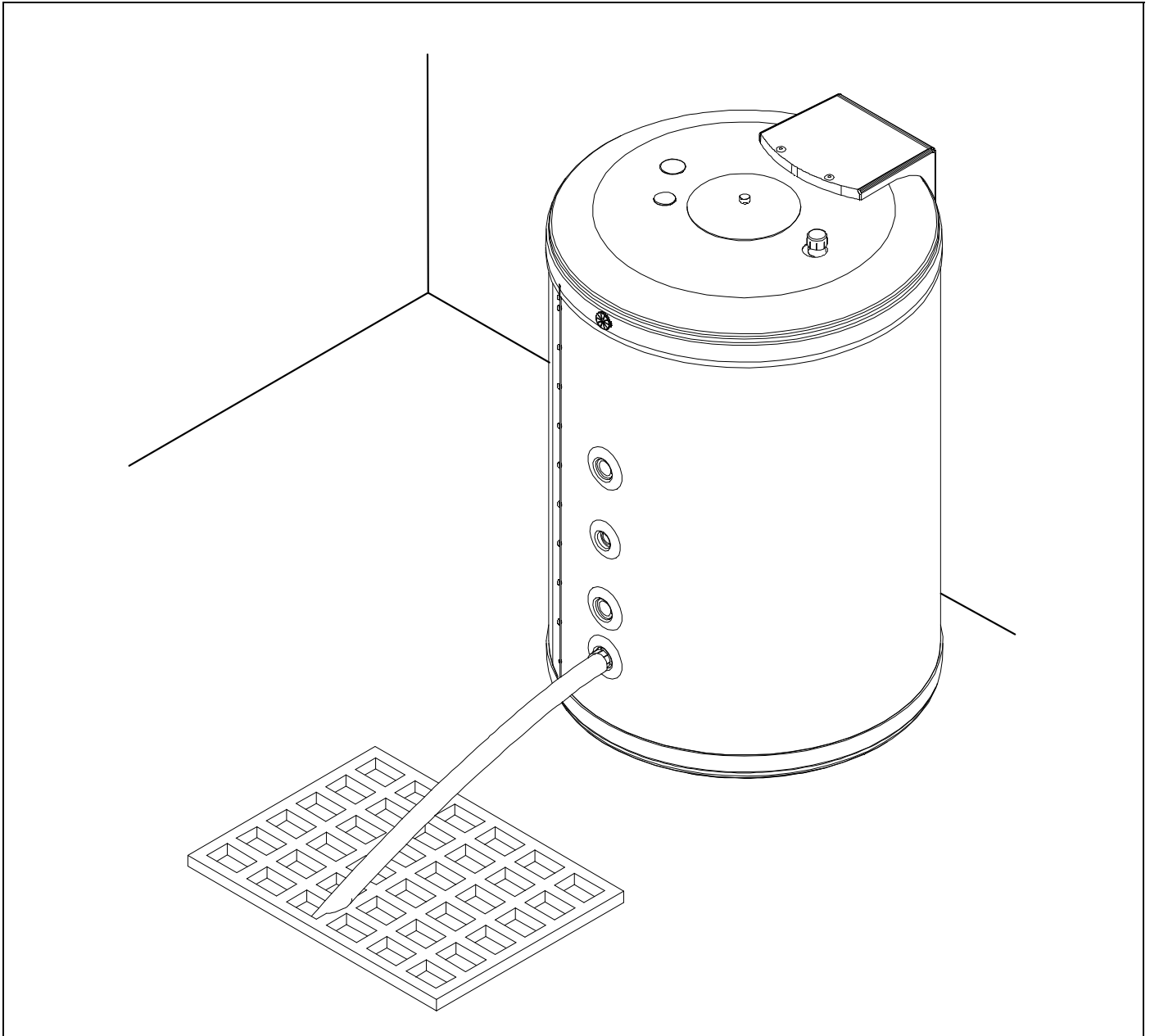

In **Sanit DCE and Sanit DC models**, the tank cover must be removed, and a flexible hose must be inserted into it. The other end of the hose must be directed towards a floor drain, so that it is at a lower level than the base of the accumulator. Next, aspirate slightly so that the water begins to flow and wait for the tank to empty completely.

8 MAINTENANCE

To keep the boiler/hot water tank unit in perfect working order, both appliances should be inspected yearly by **DOMUSA TEKNIK** authorised technicians. In particular, the following are recommended:

- The inside of the hot water tank should be thoroughly cleaned once a year. The primary circuit should be drained first, before draining the hot water tank.
- If the hot water tank includes electronic cathode protection, this should be inspected once a year to ensure it is functioning correctly.
- The pressure of the primary installation must be kept between 1 and 1.5 bars.
- Make sure the safety valve and the drain valve are working correctly.
- If the installation has been out of use for a long time, check the hot water tank feed pump is working correctly.

It is recommended for the user to periodically check the pressure and temperature levels of the hot water tank and the state of the valves, connections and accessories.

9 START-UP

For the **guarantee to be valid**, the hot water tank must be started up by an **Official DOMUSA TEKNIK Technical Assistance Service**. Before starting it up, the following must be ensured:

- The electrical connection of the hot water tank is correctly made.
- The installation is filled with water and the draining has been done correctly.
- The drain valve is working properly.
- The primary flow and return connections and the hot and cold water connections have been correctly made.
- The thermostat has been properly adjusted and the electric cabling complies with regulations.
- There are no leaks from the splices and connections.

10 DELIVERY OF THE INSTALLATION

After the initial start-up of the appliance, the Technical Assistance Service will explain to the user how the hot water tank works, making any observations they consider relevant.

It is the responsibility of the installer to explain to the user the functioning of any control devices belonging to the installation and not supplied with the hot water tank.

Sanit

11 SPARES LIST

11.1 Hot water tank

Sanit S et Sanit SE

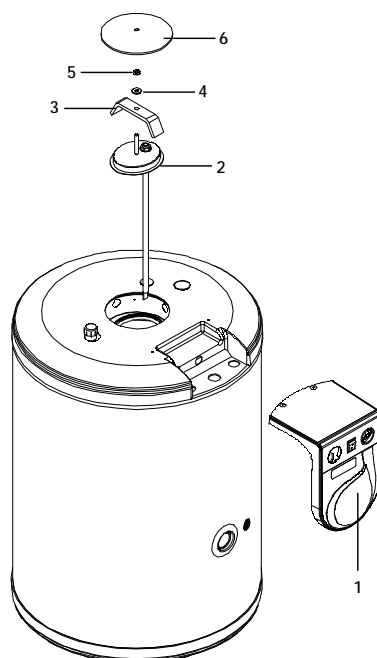

<u>Pos</u>	<u>Code</u>	<u>Name</u>
1	GELESAN007	Electrical board Sanit 100- 150 l (mod. SE)
	GELESAN009	Electrical board Sanit 200- 250 l (mod. SE)
2	SCON001566	Elliptical plug Sanit S/ SE 100 l
	SCON001568	Elliptical plug Sanit S/ SE 150 l
	SCON001570	Elliptical plug Sanit S/ SE 200 l
	SCON001571	Elliptical plug Sanit S/ SE 250 l
	SCON001572	Elliptical plug Sanit S/ SE 300 l
3	SPIN000006	Bridge
4	CTOR000080	M8 washer
5	CTOR000092	M8 nut
6	SOPE000025	Bridge cover

Sanit DCE/ DC

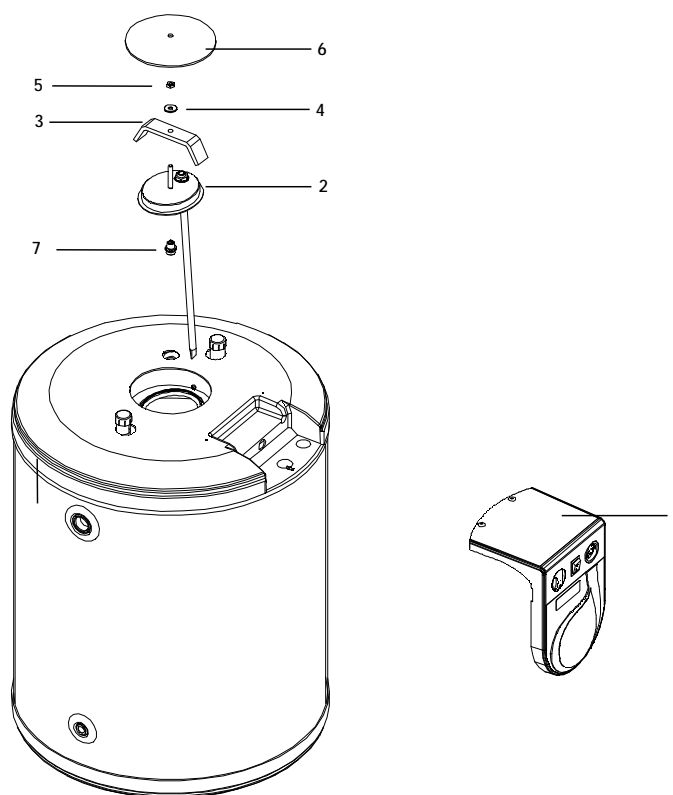

<u>Pos</u>	<u>Code</u>	<u>Name</u>
1	GELESAN007	Electrical board Sanit 100- 150 l (mod. DCE)
	GELESAN009	Electrical board Sanit 200- 250 l (mod. DCE)
2	SCON000093	Elliptical plug Sanit DCE/ DC 100 l
	SCON001567	Elliptical plug Sanit DCE/ DC 150 l
	SCON001569	Elliptical plug Sanit DCE/ DC 200 l
	SCON001784	Elliptical plug Sanit DCE/ DC 250 l
3	SPIN000006	Bridge cover
4	CTOR000080	M8 washer
5	CTOR000092	M8 nut
6	SOPE000025	Bridge cover
7	CFOV000034	Manual drain valve

Sanit HE and HE DS

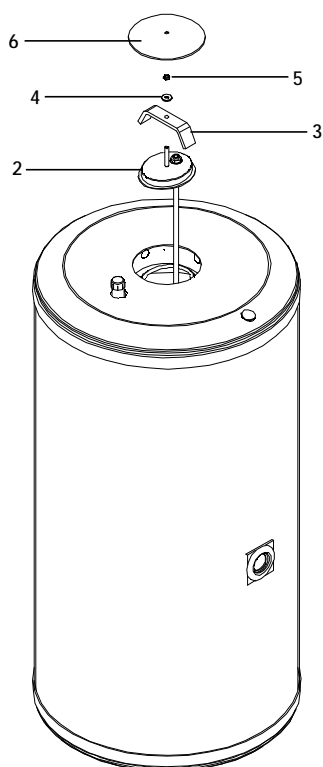

Pos	Code	Name
2	SCON001645	Elliptical plug Sanit HE 150
	SCON001642	Elliptical plug Sanit HE 200
	SCON001650	Elliptical plug Sanit HE 300
2	SCON001646	Elliptical plug Sanit HE 200 DS
	SCON001651	Elliptical plug Sanit HE 300 DS
3	SPIN000006	Bridge cover
4	CTOR000080	M8 washer
5	CTOR000092	M8 nut
6	SOPE000025	Bridge cover

11.2 Plugs and embellisher

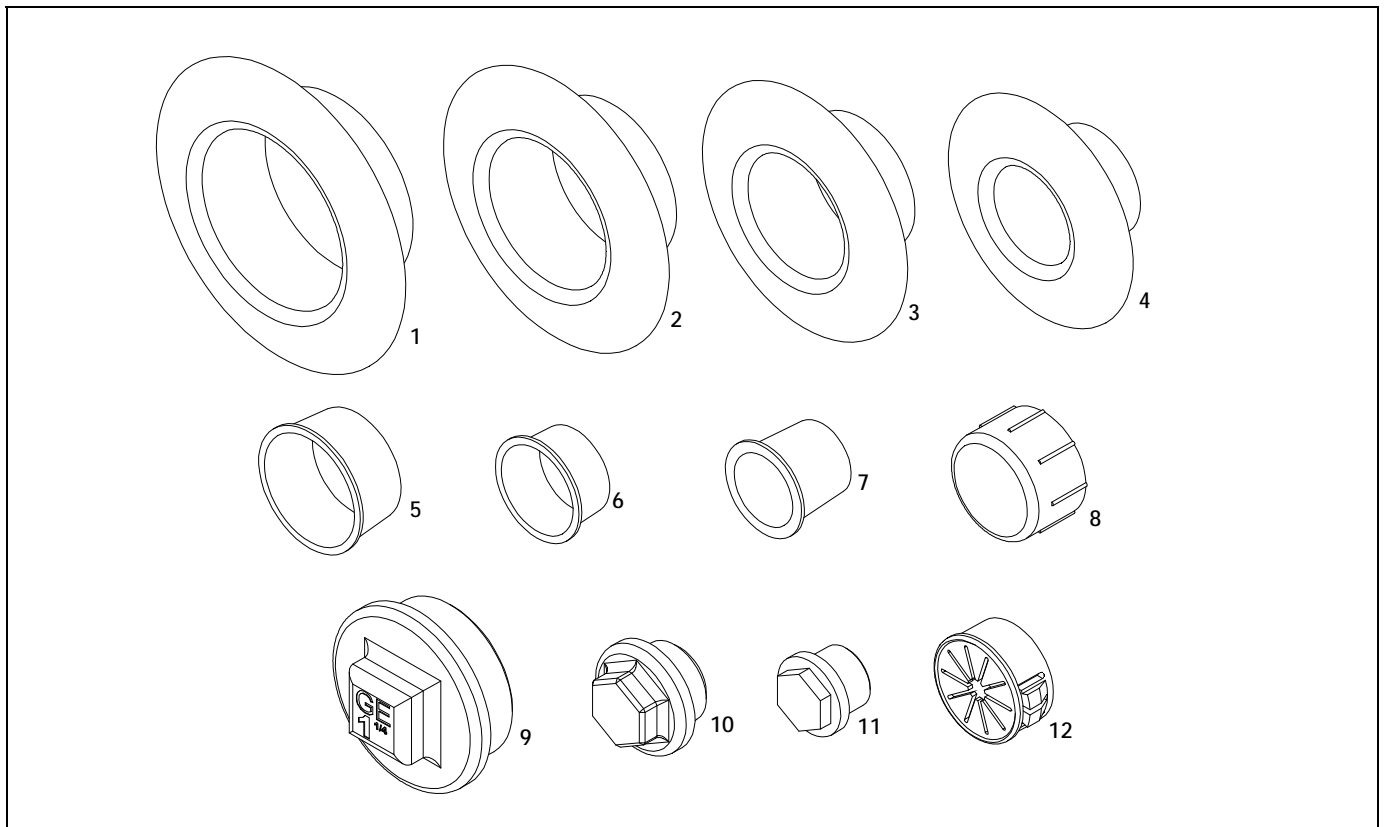

Pos	Code	Name															
			Sanit S/SE 100	Sanit S/SE 150	Sanit S/SE 200	Sanit S/SE 250	Sanit S/SE 300	Sanit DCE/DC 100	Sanit DCE/DC 150	Sanit DCE/DC 200	Sanit DCE/DC 250	Sanit HE 150	Sanit HE 200	Sanit HE 300	Sanit HE 200 DS	Sanit HE 300 DS	
1	CFER000087	1 1/4" black embellisher	1	1	1	1	1						1	1	1		
2	CFER000086	1" black embellisher			2	2	2	2	2	2	2	2		2	2	2	2
3	CFER000085	3/4" black embellisher	2	2		1	1						2		1	2	3
4	CFER000084	1/2" black embellisher	2	2	2	1	2	1	1	1	1	2	2	2	1	2	1
5	CFER000134	1" red tapered plug			2	2	2	2	2	2	2	2	2	2	2	2	2
6	CFER000082	3/4" red tapered plug	2	2		1	1								1	2	
7	CFER000049	1/2" red tapered plug	1	1	1								1	1		1	3
8	CFER000007	F 3/4" red plug	2	2	2	2	2	2	2	2	2	2	2	2	2	2	2
9	CFOL000020	M 1 1/4" chromed plug	1	1	1	1	1						1	1	1		
10	CFOL000025	M 1/2" brass plug						1	1	1	1						
11	CFOL000055	M 3/8" brass plug						1	1	1	1						
12	CFER000083	Seal	2	2	2	2	1	1	1	1	1	1	1	1	1	1	1

Sanit

11.3 Electrical board (Sanit SE and Sanit DCE)

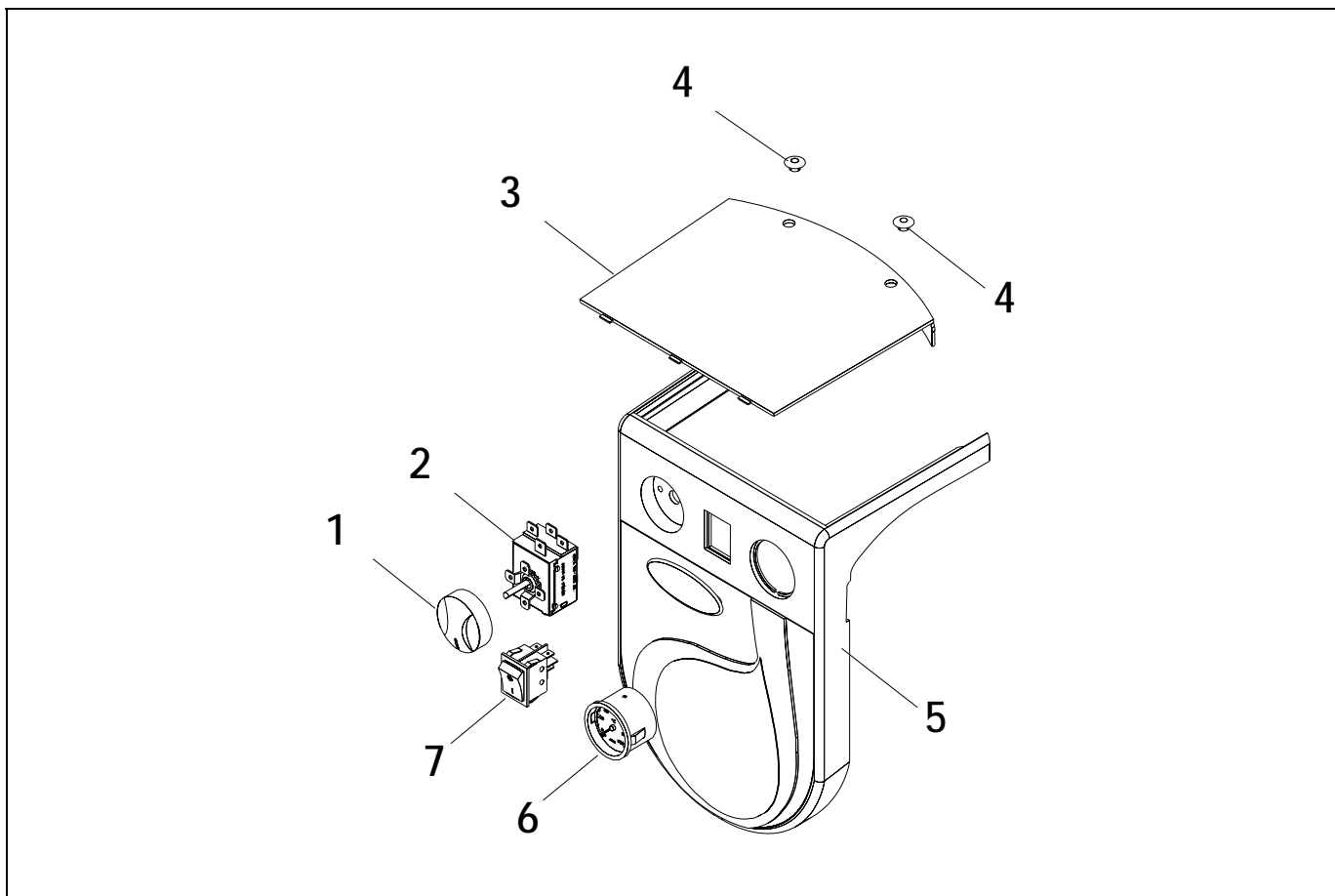

<u>Pos.</u>	<u>Code</u>	<u>Name</u>	<u>Pos.</u>	<u>Code</u>	<u>Name</u>
1	CELC000099	Knob	5	CACU000034	Control panel
2	CELC000007	Control thermostat	6	CELC000136	Thermometer
3	CACU000036	Control panel cover	7	CELC000025	Switch
4	CACU000037	Control panel plug			

12 DIAGRAMS AND MEASUREMENTS

Sanit SE, Sanit S and Sanit HE

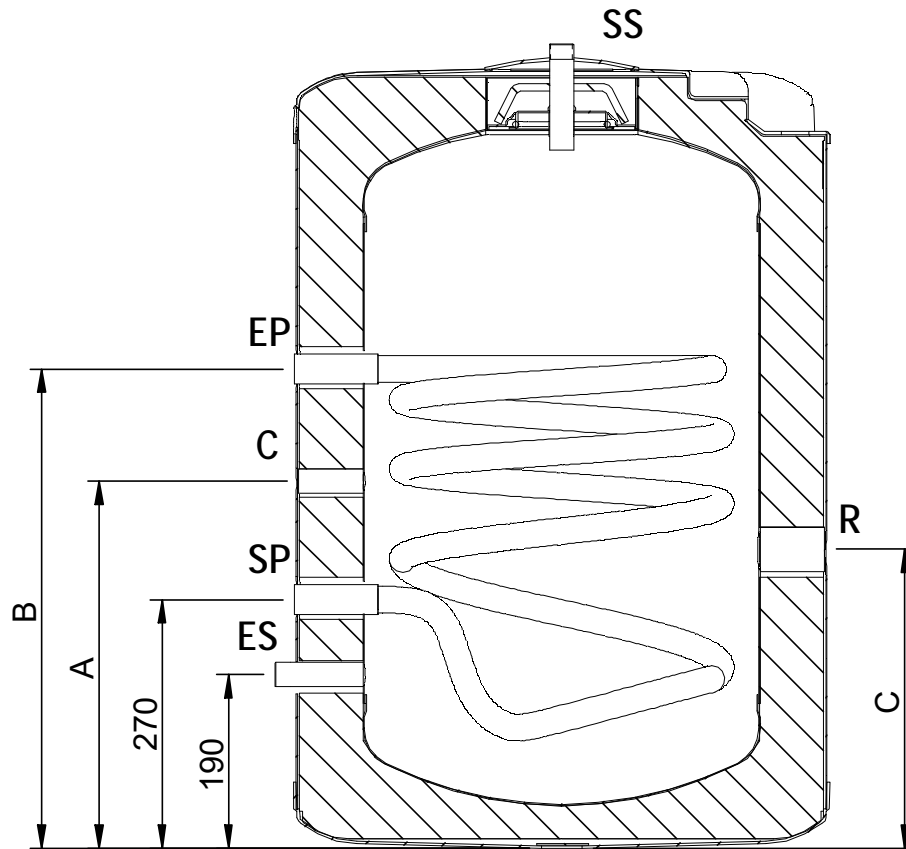

MODEL SANIT SE / S / HE		100	150	200	250	300
Base measurement	mm	Ø 581	Ø 581	Ø 581	Ø 608	Ø 608
Height measurement	mm	898	1.227	1.563	1.541	1.790
Cold water inlet	ES Ø	3/4" M	3/4" M	3/4" M	3/4" M	3/4" M
Hot water outlet	SS Ø	3/4" M	3/4" M	3/4" M	3/4" M	3/4" M
Primary inlet/outlet	EP/SP Ø	3/4" H	3/4" H	1" H	1" H	1" H
Resistance socket	R Ø	1 1/4" H	1 1/4" H	1 1/4" H	1 1/4" H	1 1/4" H
Recirculation socket	C Ø	1/2" H	1/2" H	1/2" H	3/4" H	3/4" H
SANIT SE / S						
Height C - level "A"	mm	400	645	790	810	810
Height EP - level "B"	mm	525	520	615	640	640
Height R - level "C"	mm	325	325	325	350	350
SANIT HE						
Height C - level "A"	mm	-	810	970	-	1145
Height EP - level "B"	mm	-	890	885	-	1065
Height R - level "C"	mm	-	520	520	-	645

Sanit

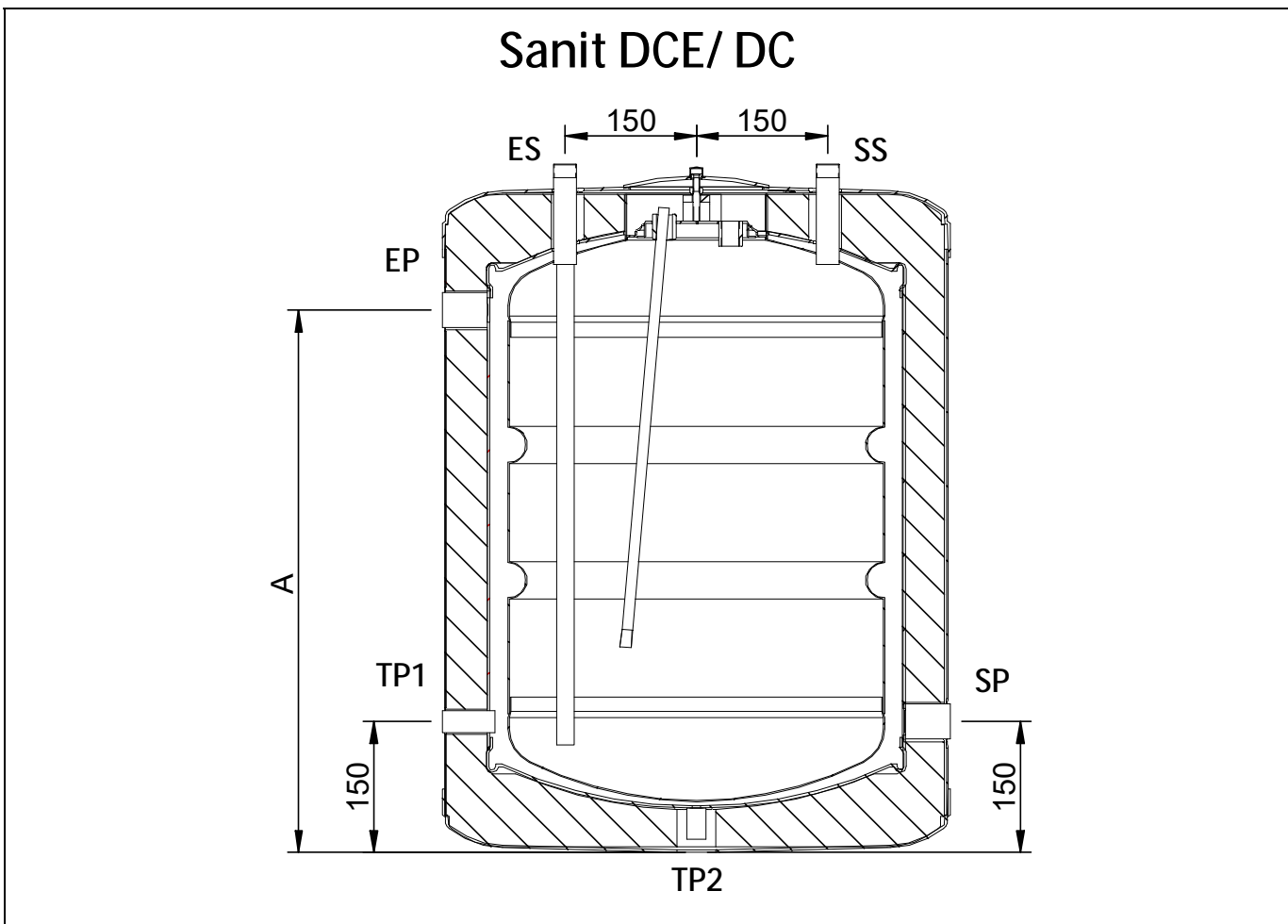

MODEL SANIT DCE/ DC		100	150	200	250
Base measurement	mm	Ø 581	Ø 581	Ø 581	Ø 581
Height measurement	mm	898	1.227	1.563	1635
TP1 drain valve socket	Ø	1/2" H	1/2" H	1/2" H	1/2" H
TP2 drain valve socket	Ø	3/8" H	3/8" H	3/8" H	3/8" H
Cold water inlet	ES Ø	3/4" M	3/4" M	3/4" M	3/4" M
Hot water outlet	SS Ø	3/4" M	3/4" M	3/4" M	3/4" M
Primary inlet/outlet	EP/SP Ø	1" H	1" H	1" H	1" H
EP - level "A"	mm	620	900	1200	1305

Sanit HE DS

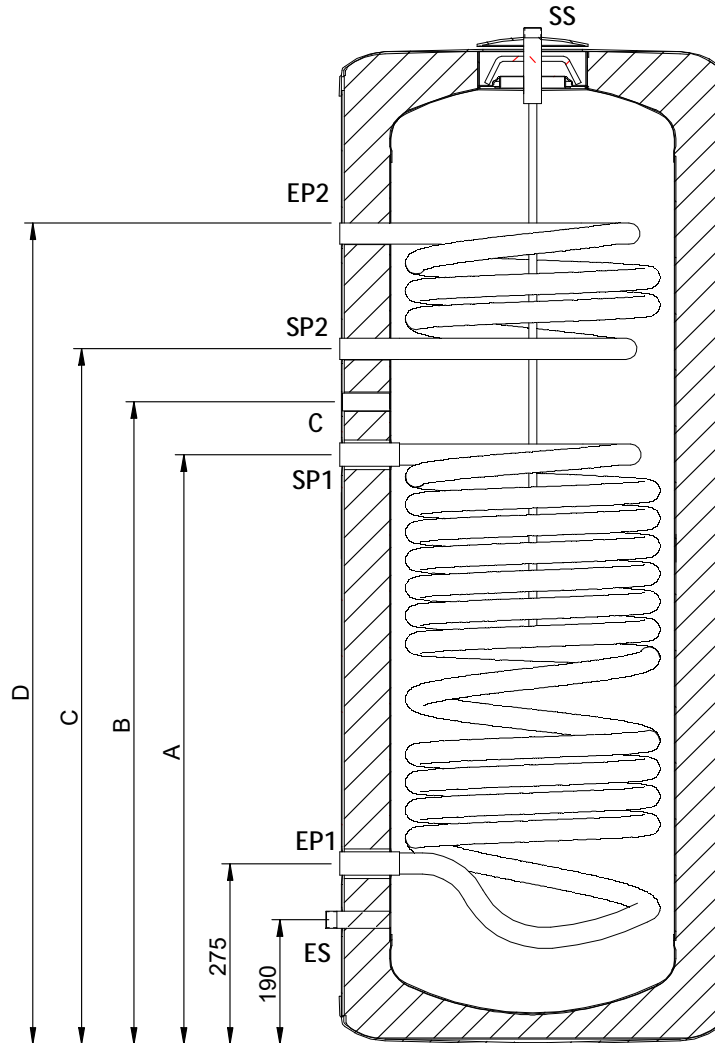

MODEL SANIT HE DS		200	300
Base measurement	mm	Ø 581	Ø 608
Height measurement	mm	1.563	1.790
Cold water inlet	ES Ø	3/4" M	3/4" M
Hot water outlet	SS Ø	3/4" M	3/4" M
Primary inlet/outlet (1)	EP/SP Ø (1)	1" H	1" H
Primary inlet/outlet (2)	EP/SP Ø (2)	3/4" H	3/4" H
Recirculation socket	C Ø	1/2" H	1/2" H
Height SP1 – level "A"	mm	890	1065
Height C – level "B"	mm	970	1145
Height SP2 – level "C"	mm	1050	1285
Height EP2 – level "D"	mm	1225	1460

Sanit

13 TECHNICAL CHARACTERISTICS

		MODEL SANIT S and SANIT SE				
		Sanit 100	Sanit 150	Sanit 200	Sanit 250	Sanit 300
Installation		Floor				
Total volume	L	100	150	200	250	300
Max. storage temperature	°C	70	70	70	70	70
Max. working pressure of hot water tank	MPa bar	0,7 7	0,7 7	0,7 7	0,7 7	0,7 7
Max. primary temperature	°C	85	85	85	85	85
Max. primary working pressure	MPa bar	0,3 3	0,3 3	0,3 3	0,3 3	0,3 3
Empty weight	Kg	49	63	79	94	110
Full weight	Kg	153	218	285	351	410
Exchange surface	m ²	0,6	0,6	0,9	0,9	0,9

		MODEL SANIT DCE/ DC			
		Sanit 100	Sanit 150	Sanit 200	Sanit 250
Installation		Wall / Horizontal			
Total volume	L	100	150	200	250
Max. storage temperature	°C	70	70	70	70
Max. working pressure of hot water tank	MPa bar	0,7 7	0,7 7	0,7 7	0,7 7
Max. primary temperature	°C	85	85	85	85
Max. primary working pressure	MPa bar	0,3 3	0,3 3	0,3 3	0,3 3
Empty weight	Kg	53	68	85	101
Full weight	Kg	153	218	285	351
Exchange surface	m ²	1	1,4	1,8	2,2

		MODEL SANIT HE			MODEL SANIT HE DS	
		Sanit 150	Sanit 200	Sanit 300	Sanit 200	Sanit 300
Installation		Suelo				
Total volume	L	150	200	300	200	300
Max. storage temperature	°C	70	70	70	70	70
Max. working pressure of hot water tank	MPa bar	0,7 7	0,7 7	0,7 7	0,7 7	0,7 7
Max. primary temperature	°C	85	85	85	85	85
Max. primary working pressure	MPa bar	0,3 3	0,3 3	0,3 3	0,3 3	0,3 3
Empty weight	Kg	65	81	113	82	114
Full weight	Kg	215	281	413	282	414
Exchange surface	m ²	2,25	2,5	3,1	2,5 + 0,6	3,1 + 0,6

NOTES:

Dotted lines for notes.

Sanit

NOTES:

.....
.....
.....
.....
.....
.....
.....
.....
.....
.....
.....
.....
.....
.....
.....
.....
.....
.....
.....
.....
.....
.....
.....
.....

DOMUSA

TEKNIK

POSTAL ADDRESS

Apartado 95
20730 AZPEITIA

Telfs: (+34) 943 813 899

HEADQUARTERS & FACTORY

Bº San Esteban s/n
20737 ERREZIL (Gipuzkoa)

www.domusateknik.com

DOMUSA TEKNIK, reserves the right to make modifications of any kind to its product characteristics without prior notice.



CDOC001679

05/11/24